

FLAT PARTS

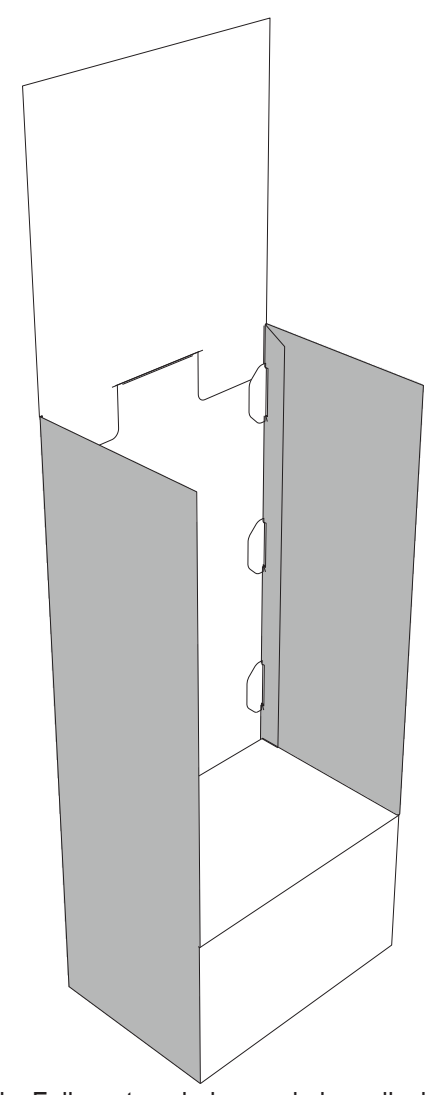

Completed assembly. Follow steps below and place display in desired location, then load with appropriate product.

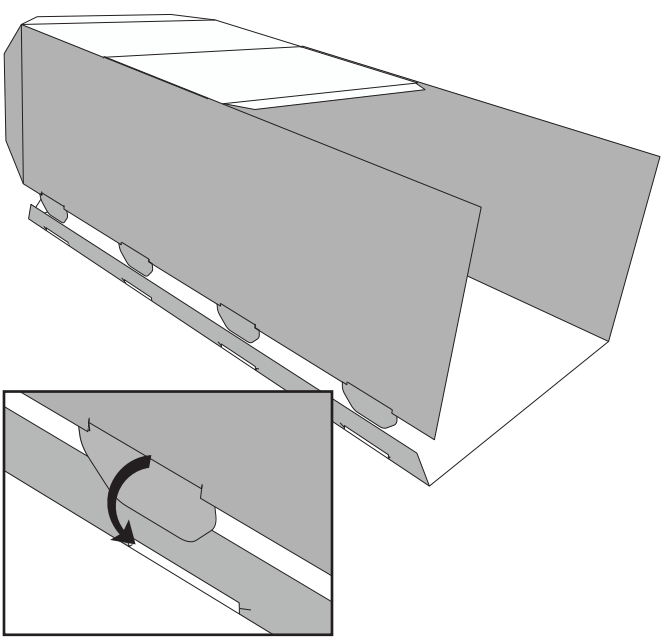

Step 1: Locate hutch and fold four main panels around to to secure with corner tabs.

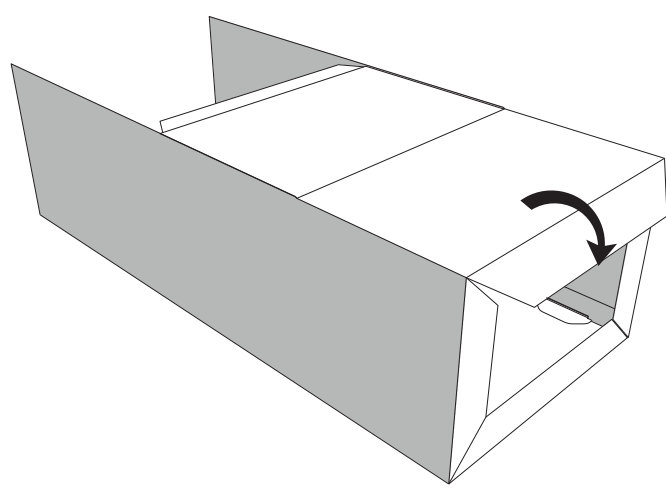

Step 2: Fold bottom flaps inward as shown.

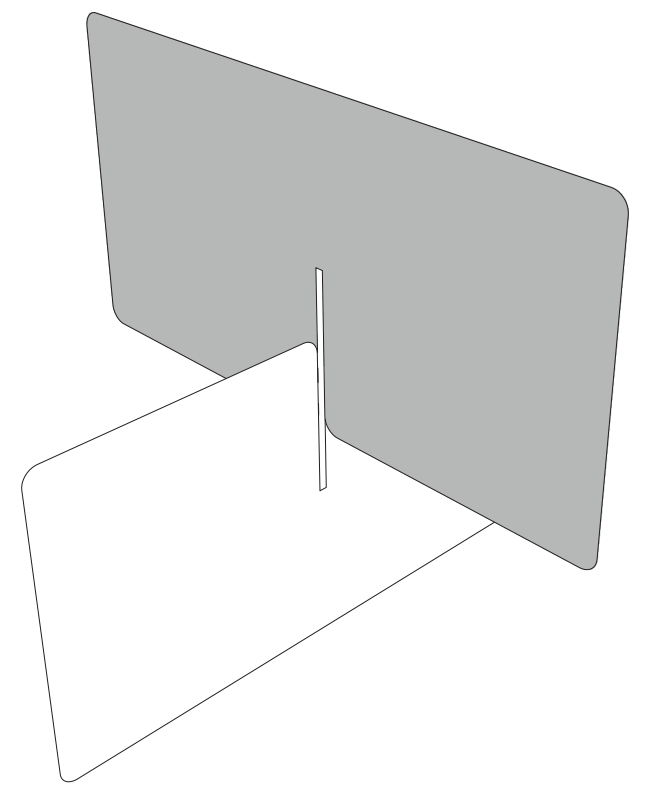

Step 3: Combine x-supports by slotting together as shown.

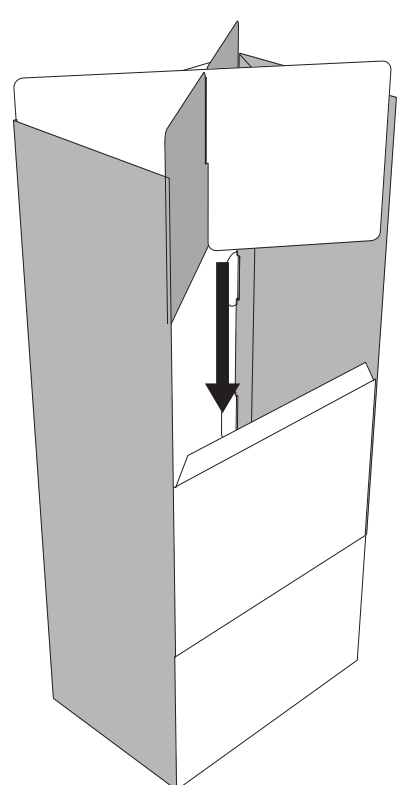

Step 4: Place combined x-supports into bottom of base.

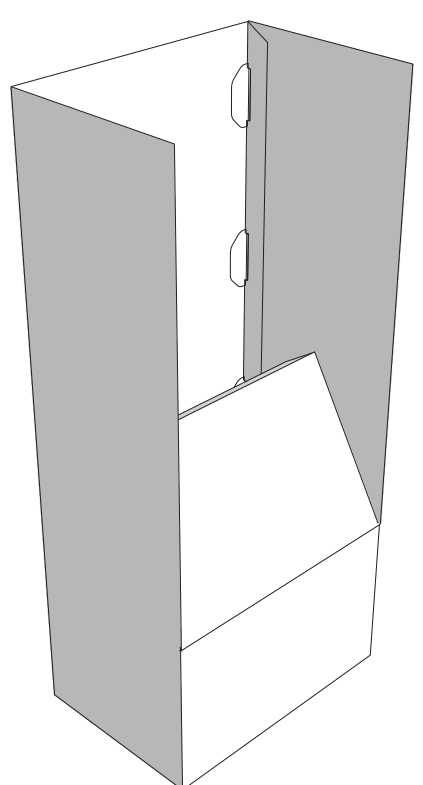

Step 5: Fold base platform and back flap inward to cover x-supports as shown.

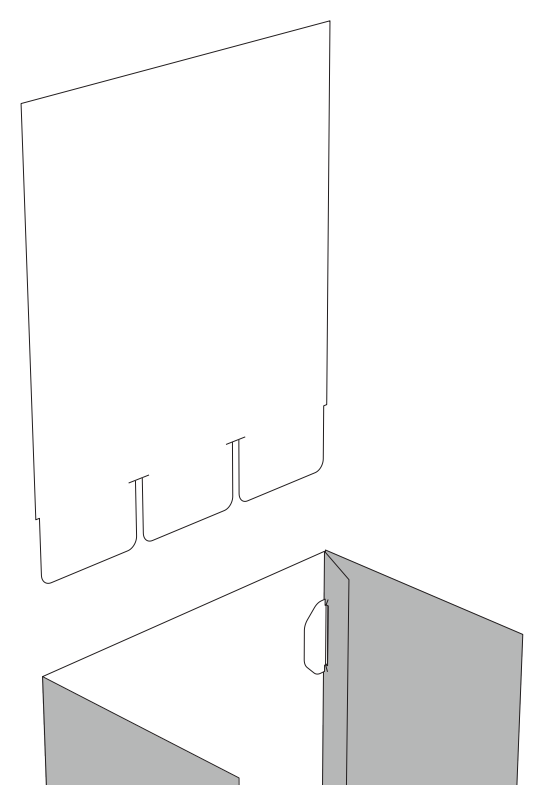

Step 6: Combine header with top of base by aligning outer flaps to the inside, and center flap behind backwall.